

APF 12/50-2

FORWARD MOVING VIBRATORY PLATE



APPLICATIONS

- Compaction in confined areas
- Asphalt and paving
- Pipeline and trench construction
- Light and medium patchwork
- Landscaping and gardening

PRODUCTIVITY

Enhanced engine performance

More powerful engine increases output and reliability under load.

Improved surface coverage

Optimized machine design and performance enhancements allow for faster completion of work over larger areas. Operators can cover more ground in less time, increasing overall productivity and reducing jobsite duration.

Compact and versatile

Highly maneuverable, ideal for urban and residential jobsites.

ERGONOMICS

Low vibration exposure

Operator-friendly HAV levels for safer and longer use.

Toolless mountable options

Quick installation of water tank, paving pad, and transport wheels without tools.

Smart design features

New, improved ergonomic handle - positioned to provide the operator with a more comfortable grip, making the machine easier and more precise to guide.

New hour meter

Simplifies tracking of operating hours and service intervals.

SERVICEABILITY

Zero daily maintenance

Thanks to the exciter system, daily service is not required.

Engine protection

Durable frame and full side covers shield the engine and vital components.

Durable components

Extended-lifetime base plate resists bending and fatigue – no welding or weak spots.

Maintenance-free exciter

Reduces service needs and downtime for higher operational efficiency.

SUSTAINABILITY

Fuel-efficient engine

Efficient combustion and reduced emissions — helping lower operating costs and environmental impact.

Longer component lifespan

Durable, maintenance-free design reduces waste and material consumption.

Less vibration, more protection

Lower HAV reduces operator strain, improving long-term jobsite sustainability.

OPTIONAL EQUIPMENT

- Paving Pad
- Transport Wheels
- Water sprinkler system
- Hour meter

STANDARD EQUIPMENT

- Vibration isolated guide handle
- High quality, wear resistant 400 mm or 500 mm base plate
- CE conformity

APF 12/50-2

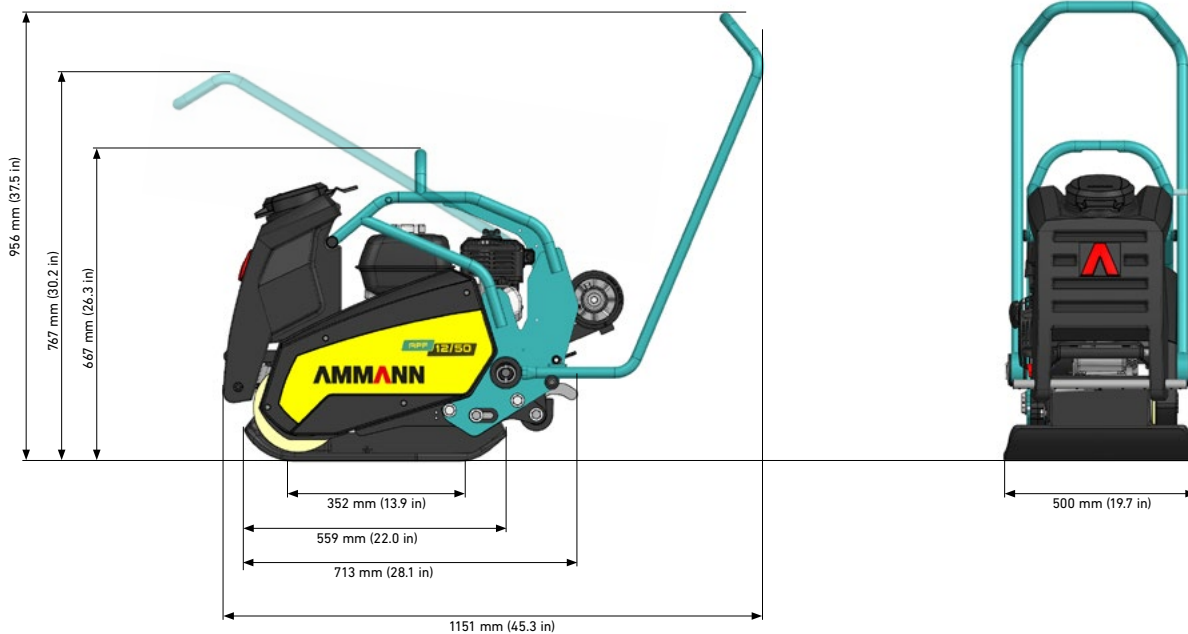

WEIGHT & DIMENSIONS

MACHINE WEIGHT BASIC UNIT	86 kg (190 lb)
ADD. WEIGHT TRANSPORT WHEELS	5,7 kg (13 lb)
ADD. WEIGHT WATER SPRINKLER SYSTEM	3,3 kg (7 lb)

ENGINE

ENGINE	Honda GX160
FUEL	Benzin
ENGINE OUTPUT	3,6 kW (4,8 HP)
AT RPM	3600
FUEL CONSUMPTION	1 l/h (0,3 US gal)

COMPACTION FORCES

MAX. VIBRATION FREQUENCY	100 Hz (6000 rpm)
MAX. CENTRIFUGAL FORCE	12 kN (2698 lbf)
MAX. WORKING SURFACE	660 m ² /h (7104 ft ² /h)
SPEC. SURFACE PRESSURE	6,8 N/cm ² (9,9 psi)

MISCELLANEOUS

HAND-ARM VIBRATIONS	< 2,5 m/sec ²
SPEED	22 m/min (0,8 mph)
FUEL TANK	3,1 l (0,8 US gal)
GRADEABILITY	30%
MAX. INCLINE TO ALL SIDES	20°
WATER TANK (SPRINKLING SYSTEM)	12 l (3,2 US gal)
AMPLITUDE	0,8 mm (0,0 in)

APF 12/50-2

For additional product information and services please visit: www.ammann.com
Materials and specification data are subject to change without notice.
MSS-3349-00-EN | © Ammann Group

AMMANN