



# APR 5920

## REVERSIBLE VIBRATORY PLATE

### MANOEUVRABLE DESPITE ITS SIZE

At 440 kg (970 lb), the APR 5920 is the heaviest of the APR vibratory plates. A high-performance diesel engine powers the machine with 6.6 kW (8.8 HP) of power. The machine delivers 59 kN (13 264 lbf) of centrifugal force. This reversible vibratory plate offers manoeuvrability and great climbing with an ability to work on 30 % grades. It is one of the fastest machines available on the market. Optional extensions of 75 mm (3.0 in) and 150 mm (5.9 in) can further improve productivity.

### INNOVATIVE HANDLE

- The low vibration handle reduce stress on the operator.
- Round handle for optimized grip for all individual operator.
- Opening in handle prevents the machine from getting damaged by lifting on unsuitable positions.

### MAKES THE GRADE

- Overcomes grades of 30 %.
- Remains fastest machine on the market.

### READY TO RENT

- Low-cost upkeep.
- Good match for many applications.
- Easy for new users to operate.

### TWIN-SHAFT EXCITER UNIT

- Shaft positioning enables the operator to easily change directions.
- Smooth variable hydrostatic unit allows machine to move easily in forward and reverse.
- “On-the-spot” vibration can be utilised in particularly challenging areas.

### DURABLE

- Engine cover to protect all components from dust and dirt.
- Well-protected, robust centrifugal clutch with wear-resistant V belt.
- Service-friendly exciter unit with long lifetime.
- Fresh air suction behind the machine leads to longer lifetime

### OPTIONAL TECHNOLOGY

- ACE<sup>econ</sup> continuously measures and monitors the compaction level

### APPLICATIONS

- Earthwork and paving applications
- Road and rail track construction
- Compaction work in narrow trenches, confined areas
- Landscape and gardening
- Foundation work
- Paving applications (with optional rubber mats for stone protection)
- Sensitive surfaces (with optional rubber mats for stone protection)

# AMMANN

TECHNICAL SPECIFICATIONS  
APR 5920 REVERSIBLE VIBRATORY PLATE

## WEIGHT & DIMENSIONS

MACHINE WEIGHT	440 kg (970 lb)
WITH EXTENSION PLATES 75 mm (3.0 in)	462 kg (1019 lb)
WITH EXTENSION PLATES 150 mm (5.9 in)	473 kg (1043 lb)
A BASE PLATE LENGTH	450 mm (17.7 in)
B MACHINE LENGTH	898 mm (35.4 in)
C WITH HANDLE	1453 mm (57.2 in)
D MACHINE HEIGHT	850 mm (33.5 in)
E HANDLE HEIGHT (WORK)	1000 mm (39.4 in)
F HANDLE HEIGHT (TRANSPORT)	1285 mm (50.6 in)
G MACHINE WIDTH	450 mm (17.7 in)

## ENGINE

ENGINE	Hatz 1B40
FUEL	Diesel
ENGINE OUTPUT AT RPM	6.6 kW (8.8 HP) 2900
FUEL CONSUMPTION	1.6 l/h (0.4 gal)

## COMPACTION FORCES

MAX. VIBRATION FREQUENCY	65 Hz (3900 vpm)
MAX. CENTRIFUGAL FORCE	59 kN (13 264 lbf)
WORKING SURFACE	945 m <sup>2</sup> /h (10 172 ft <sup>2</sup> /h)
WITH EXTENSION PLATES 3.0 in (75 mm)	1260 m <sup>2</sup> /h (13 563 ft <sup>2</sup> /h)
WITH EXTENSION PLATES 5.9 in (150 mm)	1575 m <sup>2</sup> /h (16 953 ft <sup>2</sup> /h)

## MISCELLANEOUS

SPEED	35 m/min (115 ft/min)
FUEL TANK	5 l (1.3 gal)
GRADEABILITY	30%
MAX. INCLINE ON ALL SIDES	25°

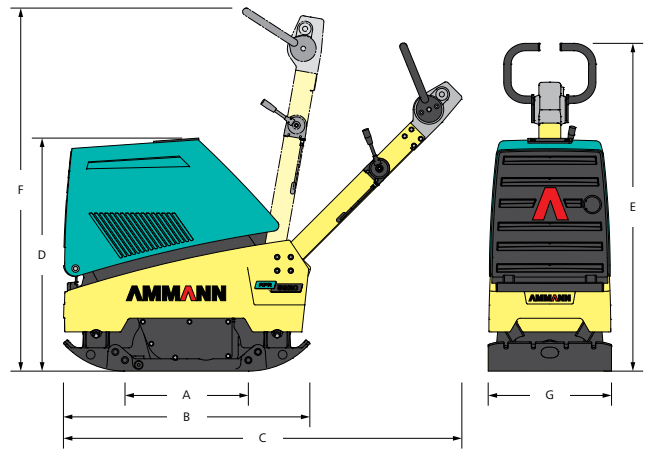

## STANDARD EQUIPMENT

- Foldable cover allows easy maintenance and assures good engine protection
- Sturdy protection frame with central lifting point
- Powerful and reliable diesel engine
- 2-shaft exciter with long service intervals
- Well protected, sturdy centrifugal clutch with wear resistant V-Belt
- 3 year extended warranty program

## OPTIONAL EQUIPMENT

- Vulcollan mat for applications on paving stones
- Electric starter (Diesel engine)
- Hour meter
- Extension plates
- ACE<sup>econ</sup>