

# ARR 1585

## TRENCH ROLLER

EU Stage V / U.S. EPA Tier 4 Final



### SKID-STEERED WORKER

The ARR 1585 is a skid-steered machine that enables powerful compaction forces to be applied to particularly difficult spots. The rammer and its padfoot drum provide results, even where other compactors have failed. Its ability to work in cohesive soils can prevent the need for soil removal and replacement, providing a significant financial savings.

#### PRODUCTIVITY

##### Compaction output

Fast, precise compaction in the fewest possible passes

##### Skid-steer concept

Unique steering properties and turning «on-spot»

##### Traction

Powerful propulsion drive system and excellent machine weight distribution for unrivaled traction in slopes

#### ERGONOMICS

##### Machine controls

Various controls are available: manual, cable control or infrared remote control

##### Infrared remote control

Safest solution; operator must have directly visibility for the machine to run.

##### Operator protection

Increased safety during machine operation

#### SERVICEABILITY

##### Maintenance-free parts

Reduce time required for machine maintenance and prevent damage to components

##### Tool-free daily inspection

Daily maintenance possible without tools

##### Protective frame and covers

Maximum protection of all key components

#### APPLICATIONS

- Pipeline construction
- Residential & industrial development areas
- Structure backfill work
- Confined work spaces
- Airport construction
- Elec. cable construction
- Dumpsite construction
- Subbase of roads

# AMMANN

TECHNICAL SPECIFICATIONS  
ARR 1585 TRENCH ROLLER  
EU Stage V / U.S. EPA Tier 4 Final

DIMENSIONS		
A	Machine length	1520 mm (59.8 in)
B	Wheelbase	850 mm (33.5 in)
C	Machine height	1230 mm (48.4 in)
F	Drum width	630 / 850 mm (24.8 / 33.5 in)
G	Machine length	1780 mm (70.1 in)
I	Drum diameter	500 mm (19.7 in)

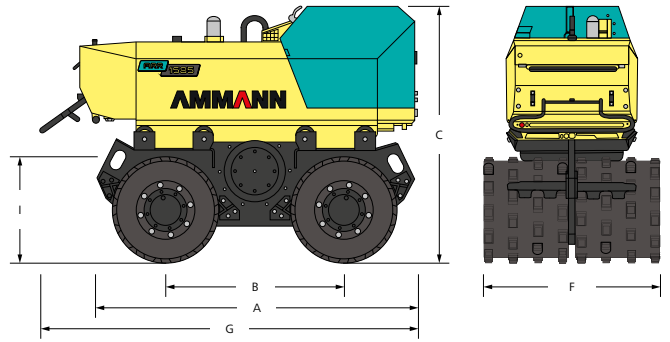

WEIGHT & OPERATING CHARACTERISTICS		
	630 mm (24.8 in)	850 mm (33.5 in)
Operating weight	1305 kg (2880 lb)	1395 kg (3080 lb)
Oscillating angle	–	–
Working speed	1.1 km/h (0.7 MPH)	1.1 km/h (0.7 MPH)
Travel speed	2.5 km/h (1.6 MPH)	2.5 km/h (1.6 MPH)
Gradeability with / without vibr.	25 % / 30 %	25 % / 30 %
Turning radius inner	0 mm (on spot)	0 mm (on spot)

COMPACTION FORCES	
Amplitude	2.4 mm (0.094 in)
Frequency	30 Hz (1800 VPM)
Centrifugal force	86 kN (19 333 lbf)

ENGINE	
Manufacturer	Hatz 2 G 40
Power Acc. ISO 3046-1	13.2 kW (18 HP)
Engine complies with emission regulations	EU Stage V / U.S. EPA Tier 4 Final
Nominal speed	2550 min <sup>-1</sup> (RPM)
No of cylinders	2 / air cooling
Drive system	Hydrostatic

MISCELLANEOUS	
Fuel tank capacity	28 l (7.4 gal)
Hydraulic oil capacity	16 l (4.2 gal)

### STANDARD EQUIPMENT

- Fully hydrostatic drive
- Skid steer
- Central and maintenance free vibratory system
- Central lifting point
- Manual control

### OPTIONAL EQUIPMENT

- Toolset
- Additional documentation printed
- Certificate of origin
- Customer colors
- Biodegradable oil